

# Pine Cone

Toshikazu Kawasaki

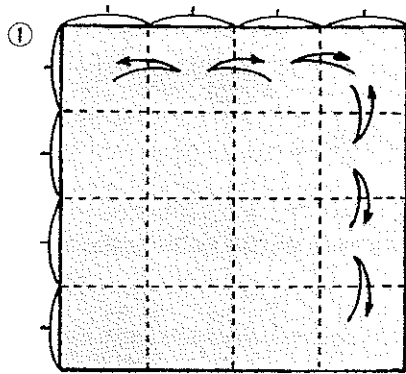

The colored side of the paper must be up.

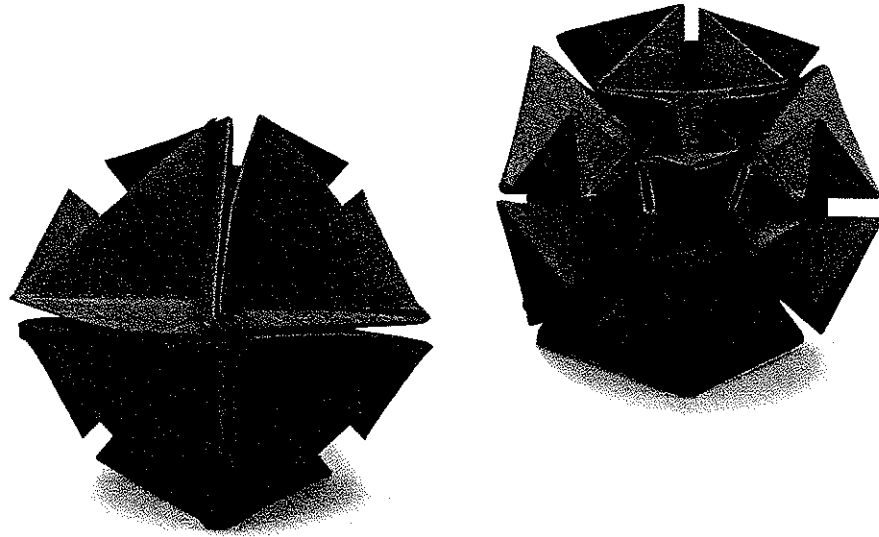
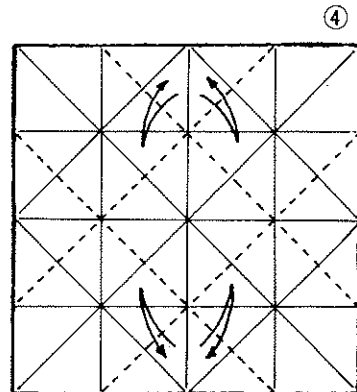
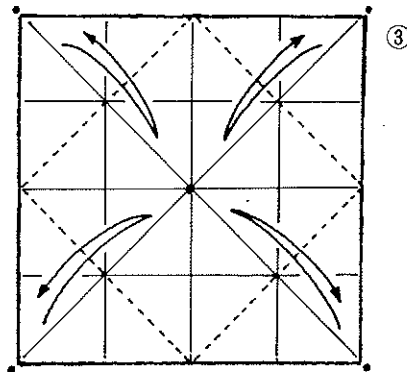
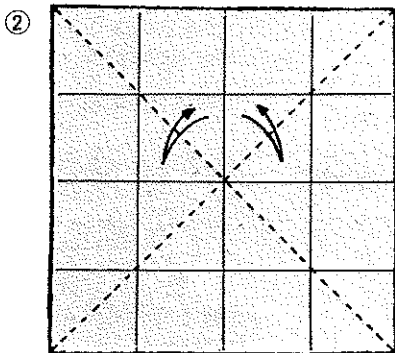

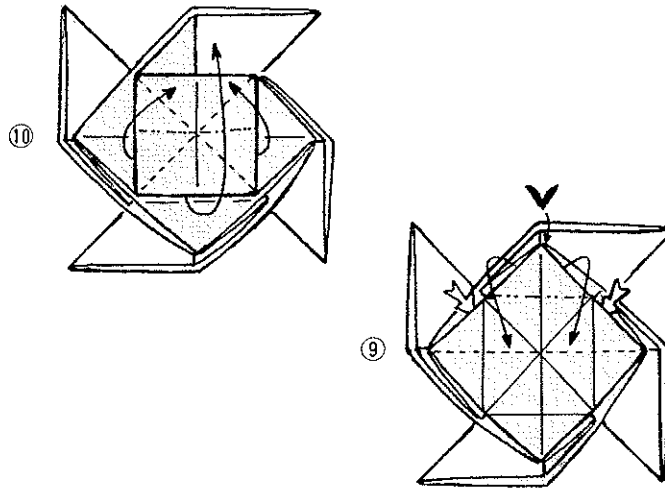
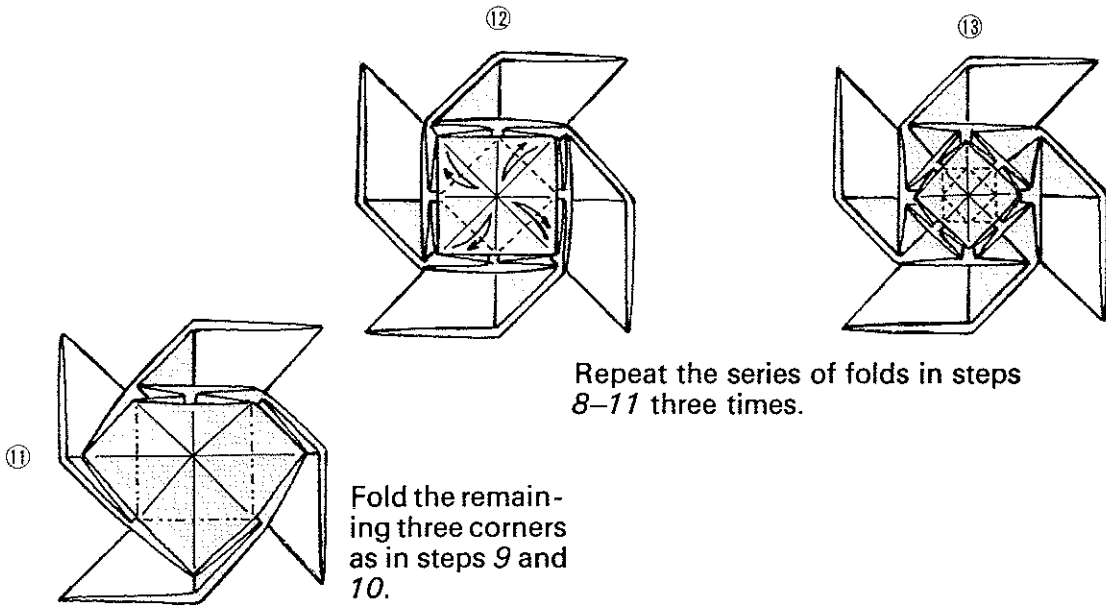

Employing the creases made to step 4 adjusts the paper into the form shown in step 7.

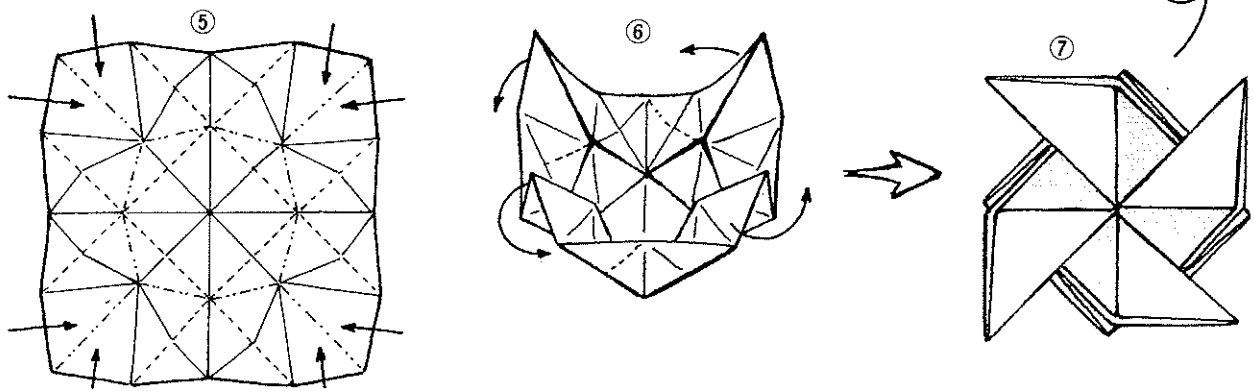

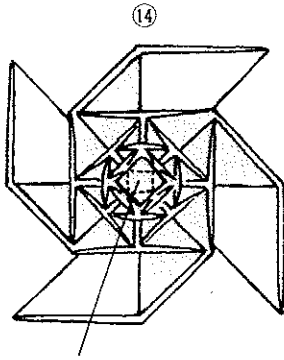

Finally, merely fold the four small corners in to the center.

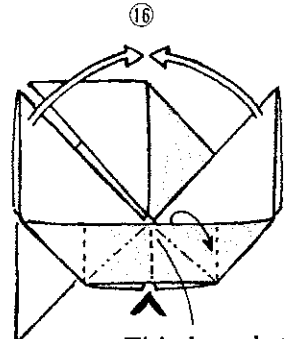
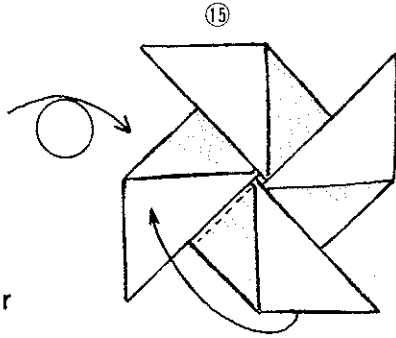

This is point *P*.

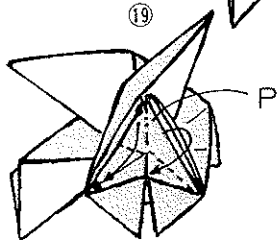
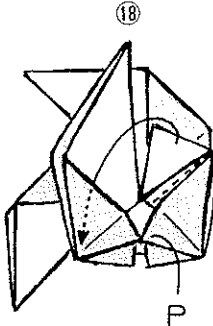
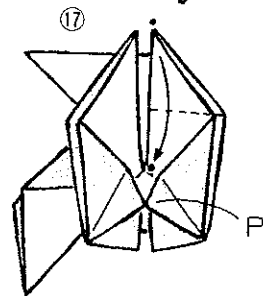

The process after step 17 entails opening the folded paper into multidimensional shape. Using point *P* as a guide, carefully interpret the parts of the form.

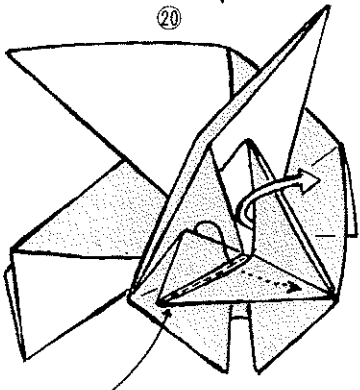

After opening the pocket on the right and folding the small corner, return the pocket to its former position and push the small corner inward.

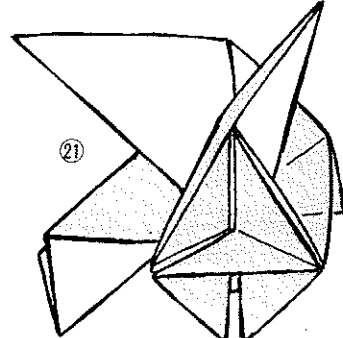

Repeating the process in steps 16–20 in the remaining three parts completes the form.